

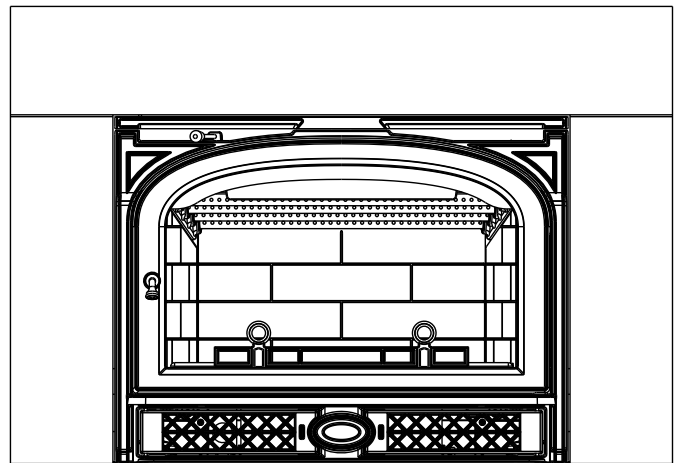

Montpelier Medium Insert Homeowner's Installation and Operating Manual



For Use in North America

SAFETY NOTICE: IF THIS APPLIANCE IS NOT PROPERLY INSTALLED, OPERATED AND MAINTAINED, A HOUSE FIRE MAY RESULT. TO REDUCE THE RISK OF FIRE, FOLLOW THE INSTALLATION INSTRUCTIONS. FAILURE TO FOLLOW INSTRUCTIONS MAY RESULT IN PROPERTY DAMAGE, BODILY INJURY OR EVEN DEATH. CONTACT LOCAL BUILDING OFFICIALS ABOUT RESTRICTIONS AND INSTALLATION INSPECTION REQUIREMENTS IN YOUR AREA.



The French language version of this manual is available online: www.vermontcastings.com
La version française de ce manuel est disponible en ligne : www.vermontcastings.com

Do Not Discard This Manual: Retain for Future Use

Introduction

Thank you for purchasing a Vermont Castings Montpelier Medium Insert, an efficient wood stove carefully engineered to bring you the latest in wood combustion principles and modern foundry technology.

This stove transforms a traditional masonry fireplace into a powerful heater. You can count on years of comfortable heating and pleasurable fire-viewing if you operate and maintain it according to the directions in this Owner's Guide.

This Insert has been tested and listed by OMNI-Test Laboratories of Portland, Oregon to UL1482-1996(R2006) for the United States and ULC S628-93 for Canada. This Insert is listed to, and in compliance with, the standards set forth by the Federal Environmental Protection Agency, 40 CFR Part 60.532(b), as stated on the permanent label attached to the stove.

This manual describes the installation and operation of this Insert. This heater meets the U.S. Environmental Protection Agency's emission limits for wood heaters sold after May 15, 2015. Under specific test conditions this heater has been shown to deliver heat at a rate ranging from 10,100 to 27,550 BTU/hr.

For more complete details on stove performance and specifications, please refer to Page 3.

The Montpelier Medium Insert is designed, tested and listed for burning wood. Do not burn other fuels.

Installation or service of the Montpelier Medium Insert should be performed only by a qualified installer, preferably NFI or WETT (Canada) certified.

Please read entire manual before you install and use your new Insert.

Failure to follow these instructions may result in property damage, bodily injury or even death.

Save These Instructions for Future Reference

Table of Contents

Specifications	3
Installation	4
Smoke Alarm/Safety Tip	10
Operation.....	11
Maintenance	14
Optional Accessories	17
Replacement Parts	18
Warranty	20

Proposition 65 Warning: Fuels used in gas, wood-burning or oil fired appliances, and the products of combustion of such fuels, contain chemicals known to the State of California to cause cancer, birth defects and other reproductive harm.
California Health & Safety Code Sec. 25249.6

The Montpelier Medium Insert is designed, tested and listed for burning wood. Do not burn other fuels.

The Montpelier Medium Insert is not listed for mobile home installations.

Failure to follow these instructions may result in property damage, bodily injury or even death.

WARNING

This stove has not been tested with an unvented gas log set. To reduce the risk of fire or injury, do not install an unvented gas log set into this fireplace.

Specifications

Montpelier Medium Insert

EPA Emissions Rating	3.0 g/hr
Efficiency, HHV*	69%
Range of heat output**	10,100 - 27,550 BTU/hr
Maximum heat output***	40,000 BTU/hr
Area heated****	1,500 sq. ft.
Size of wood splits	18"-22" (460 - 560 mm)
Fuel Capacity	30lbs. (13.5kg)
Loading	Front
Flue size	6" (150mm)
Fireplace Insert weight	335 lbs. (152 kg)
Primary Air Control	Manual
Glass panel	High-temperature ceramic
Flue exit position	Top
Blower rating	150 cfm. (115V, 60Hz)
Power Cord Length	6 foot useable installed

*Efficiency determined by CSA B415.10.

**Under specific test conditions used during EPA emissions standard testing.

***This value can vary depending on how the unit is operated, and the type and moisture content of the fuel used. The figure shown is based on maximum fuel consumption obtained under laboratory conditions and with average efficiencies.

****These values are based on operation in building-code conforming homes under typical winter climate conditions in New England. If your home is of nonstandard construction (e.g. unusually well insulated, not insulated, built under ground, etc.) or if you live in a more severe or more temperate climate, these figures may not apply. Since so many variables affect performance, consult your Vermont Castings' Authorized Dealer to determine realistic expectations for your home.

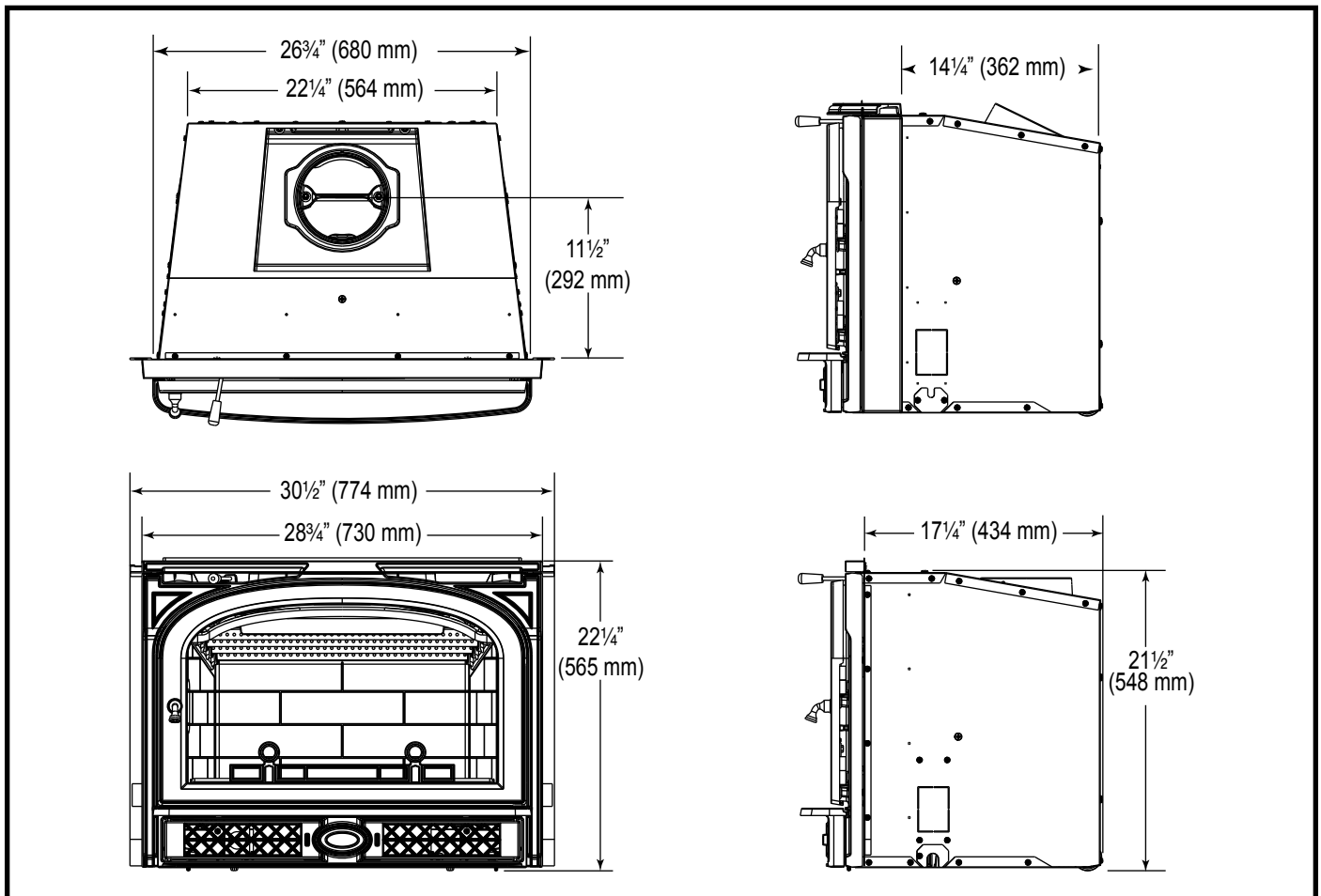

Fig. 1 Montpelier Medium Insert dimensions.

Installation

SAFETY NOTICE: IF YOUR MONTPELIER MEDIUM INSERT IS NOT PROPERLY INSTALLED, A HOUSE FIRE MAY RESULT. TO REDUCE THE RISK OF FIRE, FOLLOW THE INSTALLATION INSTRUCTIONS. CONTACT LOCAL BUILDING OR FIRE OFFICIALS ABOUT RESTRICTIONS AND INSTALLATION INSPECTION REQUIREMENTS IN YOUR AREA.

Requirements for Existing Fireplaces

The Montpelier Medium Insert is listed for installation within a properly built masonry or heat circulating, masonry-type fireplace that is constructed in accordance with the requirements of recognized building codes. A heat-circulating masonry-type fireplace must conform to building code standards for masonry fireplaces, and must consist of a factory-built metal firebox with air circulation pathways that are surrounded by masonry materials. Air circulation pathways must not be blocked by the insert or surround panels.

The fireplace and chimney must be clean and structurally sound. Have them inspected by a qualified professional chimney sweep, a mason, or your Vermont Castings' Authorized Dealer before the Montpelier Medium Insert is installed. Any deterioration (cracks, loose mortar or loose bricks) must be repaired.

Codes may permit removal of the damper in order to make a positive vent connection between the firebox and the chimney. However, the fireplace should not be modified in any way without first checking with your local building inspector or fire marshal. Provision should be made to restore the fireplace to its original condition if the insert is removed. Do not remove bricks or mortar that may jeopardize the compliance of the fireplace with local building codes.

The Montpelier Medium Insert is not listed for installation in factory-built fireplaces.

Requirements for Existing Chimneys

Chimney requirements differ for the U.S. and Canada. Specifications for each are listed below. Connect the insert to the chimney in accordance with local codes and the requirements of the listing agency as specified in this manual.

Chimney Height / U.S. and Canada

Chimney height should be no less than 15' (4.5 m) above the hearth and no more than 35' (10.5 m).

The chimney should extend at least 3' (914 mm) above the highest point where it passes through a roof, and at least 2' (610 mm) higher than any portion of a building within 10' (3 m). (Fig. 2)

DO NOT CONNECT YOUR MONTPELIER MEDIUM INSERT TO A CHIMNEY FLUE SERVING ANOTHER APPLIANCE.

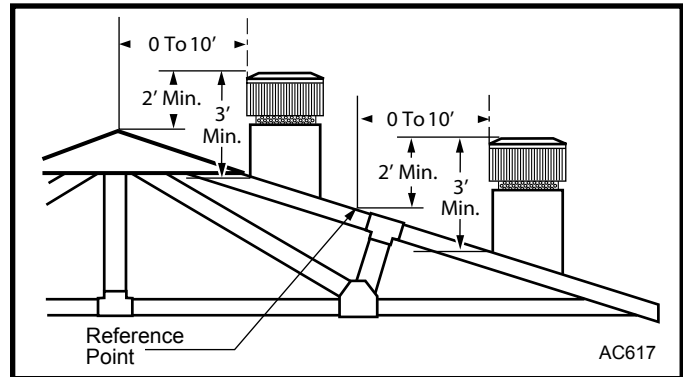

Fig. 2 The 2'-3'-10' rule for chimneys.

U.S.

In the U.S. (ANSI/NFPA 211, 1988), when installed in a masonry fireplace:

- A connector must extend from the flue collar to the flue liner.
- If a stainless steel liner is not used, the connector must extend at least four (4) feet from the flue collar of the insert.*
- The cross sectional area of the flue must be less than or equal to three times the area of the flue collar. If larger, the chimney must be re-lined.
- Means must be provided to prevent room air passing to the chimney cavity.
- Provision must be made for removal of the insert to clean the chimney flue.

General Considerations / U.S.

- While not required in most jurisdictions in the U.S., Vermont Castings Group strongly recommends that a full stainless steel chimney liner be installed for the insert to the chimney top to increase overall performance and to ease and reduce yearly maintenance.
 - A masonry chimney must be well-constructed and must meet minimum code requirements. The chimney flue should have a code-approved liner made of masonry or pre-cast refractory tiles, straight or flexible stainless steel pipe, or a poured-in-place liner. An unlined chimney must be relined professionally.
 - The chimney must have a nominal flue size of 6" (152 mm) diameter or 28 square inches (181 cm²) but no greater than 3 times larger or 85 square inches (548 cm²). A chimney larger than this must be re-lined.
- Be aware that a chimney originally designed for fireplace use may perform differently when used to vent an air-controlled appliance such as your Montpelier Medium Insert - even if the flue is less than 3 times larger than the flue collar. For example, a chimney on an outside wall may

* This requirement is in addition to those specified in ANSI/NFPA211.

not heat up enough to sustain an adequate draft. Such a flue can often be improved if it is relined to reduce its size and/or insulated to keep it warmer.

- A positive flue connection must be made between the Insert and the first masonry tile or prefabricated metal chimney section. A positive flue connection consists of a plate that seals or replaces the fireplace damper and a section of chimney connector that passes through the plate into the chimney.
- The chimney connector must be a minimum equivalent to a 6" (152 mm) diameter opening and must be 24 gauge or heavier stainless steel. The connector must extend four (4) feet measured from the collar of the insert.

Chimney Connection systems are available from a variety of manufacturers. Your Vermont Castings dealer can recommend a system that will best meet the requirements of your particular installation.

Sealing Requirements / U.S.

- The chimney must be sealed off from room air, either by a plate at the damper level or by sealing the fireplace opening.
- Unused openings to the flue must be sealed with masonry to the thickness of the chimney wall. Openings sealed with pie plates or wallpaper are a hazard. In the event of a chimney fire, flames and smoke may be forced from the openings.

Canada

In Canada (CAN/CSA-B365-M91, Section 5), whether installed in a masonry or factory built fireplace:

- This fireplace insert must be installed with a continuous chimney liner of 6" (152 mm) diameter extending from the fireplace insert to the top of the chimney. The chimney liner must conform to the Class 3 requirements of CAN/ULC-S635, *Standard for Lining Systems for Existing Masonry or Factory-Built Chimneys and Vents*, or CAN/ULC-S640, *Standard for Lining Systems for New Masonry Chimneys*.
- The opening of the fireplace around the insert must be sealed to prevent room air passing to the fireplace cavity.
- Existing air-circulation chambers in a fireplace with a steel liner may not be blocked.
- Provision must be made for removal of the insert to clean the chimney flue.
- The existing fireplace damper (if any) should be locked in the open position.

- A permanent metal warning label must be affixed to the back of the fireplace stating the fireplace may have been altered to accommodate the insert, and may be unsafe to use as a conventional fireplace. (A Fireplace Modification Tag is included in the hardware bag inside the Montpelier Medium Insert.)

Minimum Fireplace Dimensions

The Montpelier Medium Insert will fit most fireplaces. To confirm that it will fit yours, measure the lintel depth, plus the height, width, and depth of your fireplace and hearth. Compare them to the measurements in the accompanying chart. If you choose to install a new hearth over an existing fireplace hearth, be sure to take its thickness into consideration when measuring both front and back height of the fireplace and clearances to any existing trims and mantels.

The unit can be installed virtually flush with the fireplace opening or it can extend 3" (76 mm) onto the hearth using the optional 3" Hearth Extension Kit. Figure 3 gives minimum and maximum dimensions for fireplaces which will accommodate the Montpelier Medium Insert in the flush mount configuration and using the optional extension kit.

NOTE: The clearance between the Montpelier Medium Insert and the mantel, top trim and side trim cannot be reduced by installing shields.

Another requirement to consider is the clearance for movable items such as tables, bookcases, rugs, furnishings, and your woodbox. All combustible materials of this type should be a minimum of 48" (1220 mm) from the front surface of the Montpelier Medium Insert. Be sure that family members are aware of this requirement as well, so they too will keep objects a safe distance from the Montpelier Medium Insert.

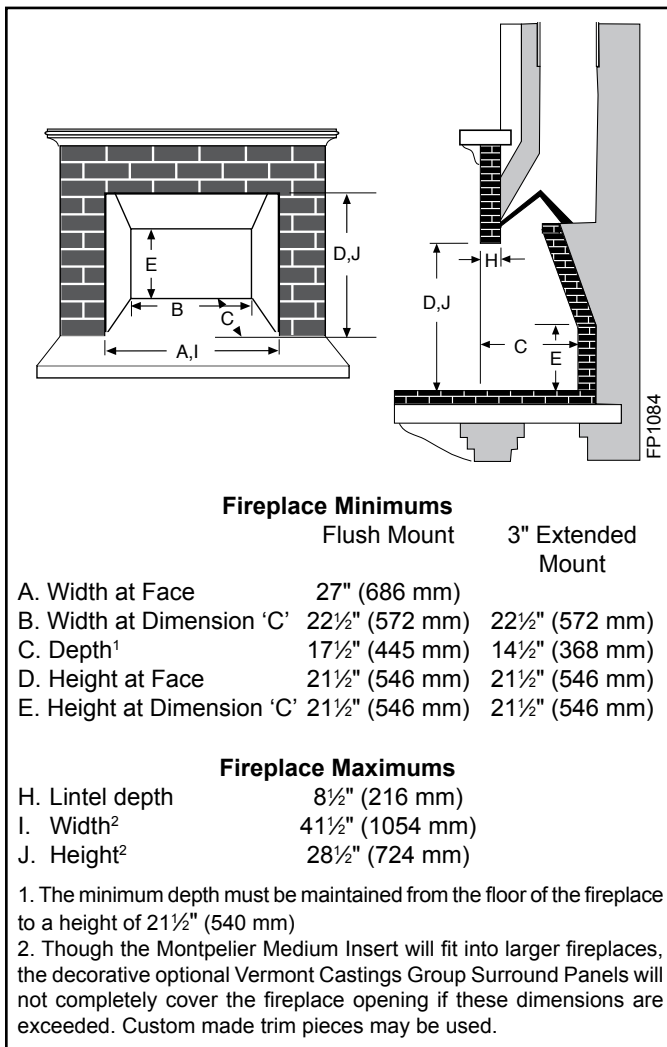

Fig. 3 Use these measurements to confirm that the Montpelier Medium Insert will fit into your masonry fireplace.

Clearance Requirements

After confirming that your fireplace is the right size, check the clearance to combustibles. First mark with tape the exact center of your fireplace opening on the hearth. Measure the side clearance from this point. Measure the top trim and/or mantel clearances from the finished hearth surface. Measure the front clearance (to furnishings, etc.) from the fireplace face. (Fig. 4)

Hearth Requirements

In some fireplaces, the hearth in front of the fireplace opening is brick, stone, slate, or some other non-combustible material that is in direct contact with concrete poured over earth. These are the only hearths that are considered noncombustible. In other fireplaces, the brick or concrete hearth in front of the fireplace opening is supported by heavy wooden framing. Because neither brick nor concrete has good insulating properties, heat radiated by the fire will pass downward through the hearth to the wooden framing. Such hearths are considered combustible.

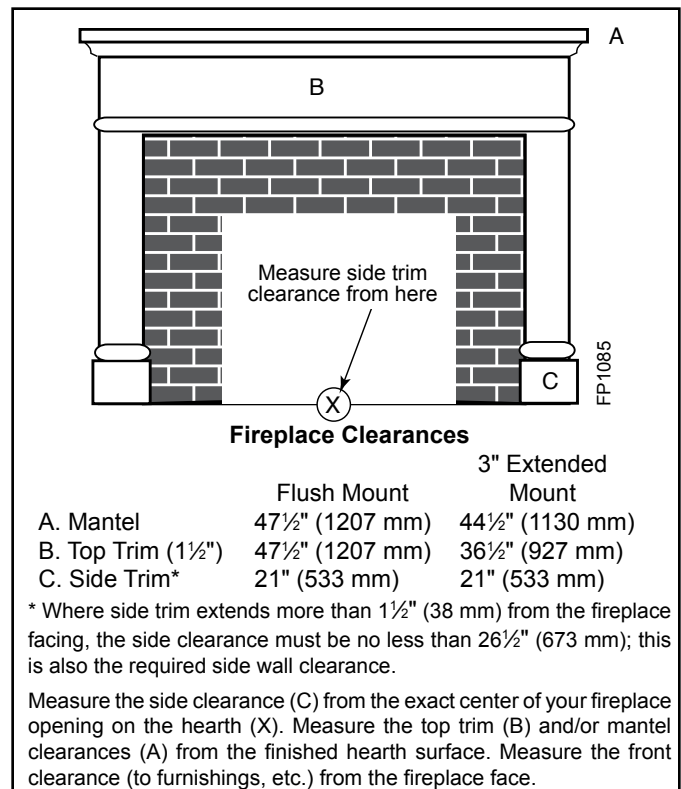

Fig. 4 Observe these clearances to combustible trim.

Unless the fireplace and hearth are constructed over a completely non-combustible surface (such as unpainted concrete over dirt), a thermal floor protector must be used in front of and to the sides of the door as protection against spilled coals and embers and heat radiated from the front of the insert. Floor protectors must extend at least 8" (203 mm) from the side of the insert, making the protector 44¾" (1137 mm) wide.

In addition, the floor protector must extend from the front door opening a minimum of 16" (406 mm) in the United States and 18" (457 mm) in Canada. (Fig. 5)

The approved construction of a floor protector calls for a minimum of 24 gauge galvanized sheet metal or equivalent, and the equivalent of 1.25" (32 mm) of a material with k-value of 0.84 or less.

Custom-made floor protectors may be used if they offer the same protection. Millboard has a standard k value of 0.84 and thus 1¼" (32 mm) of this material is adequate thermal protection. Custom-built floor protectors must have a k value equal to, or less than 0.84, meaning that heat will transfer at the same rate or more slowly than the tested standard.

How to Determine if Alternate Floor Protection Materials are Acceptable

All floor protection must be noncombustible (i.e. metals, brick, stone, mineral fiber boards, etc.). Any organic materials (i.e. plastics, wood paper products, etc.) are combustible and must not be used. The floor protection specified

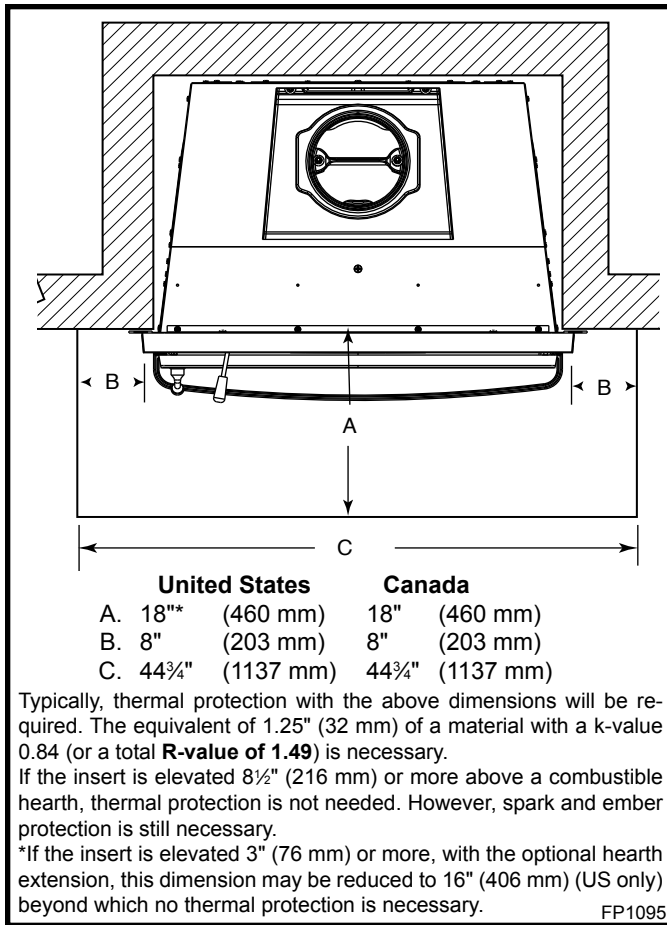

Fig. 5 Unless your fireplace and hearth are constructed over a dirt floor (or unpainted concrete over dirt), you must use a floor protector that satisfies the above requirements.

includes some form of thermal designation such as R-value (thermal resistance) or k-factor (thermal conductivity).

Procedure:

1. Convert specifications to R-value:
 - i. R-value given - no conversion needed.
 - ii. k-factor is given with a required thickness (T) in inches: $R = \frac{1}{k} \times T$
 - iii. K-factor is given with a required thickness (T) in inches: $R = \frac{1}{K \times 12} \times T$
 - iv. r-factor is given with a required thickness (T) in inches: $R = r \times T$
2. Determine the R-value of the proposed alternate floor protector:
 - i. Use the formula in Step 1 to convert values not expressed as R.
 - ii. For multiple layers, add R-values of each layer to determine overall R-value.
3. If the overall R-value of the system is greater than the R-value of the specified floor protector, the alternate is acceptable.

EXAMPLE: The specified floor protector should be 1¼" thick material with k-factor of 0.84. The proposed alternate is 4" brick with an r-factor of 0.2 over ¼" mineral board with a k-factor of 0.29

Step a: Use formula above to convert specification to R-value: $R = \frac{1}{k} \times T = \frac{1}{0.84} \times 1.25 = 1.49$

Step b: Calculate R of proposed system.

4" brick of r = 0.2, therefore:

$$R_{\text{brick}} = 0.2 \times 4 = 0.8$$

1/8" mineral board of k = 0.29, therefore

$$R_{\text{mineralboard}} = \frac{1}{0.29} \times 0.25 = 0.431$$

$$R_{\text{total}} = R_{\text{brick}} + R_{\text{mineralboard}} = 0.8 + 0.431 = 1.66$$

Step c: Compare proposed system Rtotal of 1.66 to specified R of 1.49. Since proposed system Rtotal is greater than required, the system is acceptable.

Definitions

$$R = \frac{(\text{ft}^2)(\text{hr})(^\circ\text{F})}{\text{Btu}}$$

$$k = \frac{(\text{Btu})(\text{in})}{(\text{ft}^2)(\text{hr})(^\circ\text{F})} = K \times 12$$

$$K = \frac{(\text{Btu})(\text{ft})}{(\text{ft}^2)(\text{hr})(^\circ\text{F})}$$

$$r = \frac{(\text{ft}^2)(\text{hr})(^\circ\text{F})}{(\text{Btu})(\text{in})} = \frac{1}{k}$$

Optional Surround Packages

Custom-made surround panels may be made from any noncombustible material.

Vermont Castings Group offers both steel and cast iron Surround panel kits, each in two sizes.

Georgian Cast Surround.....Enclosure Area

- 30DVSGTKCB,
- 30DVSGTKB.....30¼" x 41" (768 x 1041 mm)

Mead Cast Surround:

- MEAD3CB28¼" x 41½" (718 x 1059 mm)

Caprice Cast Adjustable Profile Surround:

- CAPCB 25" x 35" (635 x 889 mm)

Steel Surround:

- LHE30SSB.....27" x 38¼" (686 X 972 mm)
- LHE30SLB.....28¼" x 41" (718 x 1041 mm)

Installing the Montpelier Medium Insert

1. Remove or Disable the Fireplace Damper. If codes allow, remove the damper. Many dampers can be removed simply by removing a cotter pin and/or a set screw.

If it is not permissible or possible to remove the damper, secure the damper in the fully open position.

~ NOTE: CANADIAN INSTALLATIONS ~

In accordance with CAN/CSA B365-M91, you must permanently secure the Fireplace Modification Tag to the rear of the fireplace cavity if you have modified the fireplace in any way to accommodate installation of a fireplace insert. This tag is in the hardware bag included with your Insert.

2. Install the Floor Protector. Make sure the floor protector satisfies the requirements discussed on Page 6. The finished height of the floor protector or raised hearth needs to be considered before installing the venting system.

3. Flue collar orientation: The flue collar may be oriented in the vertical position or rotated 180 degrees on the top of the stove resulting in a 26 degree backward angle. If possible, determine beforehand which orientation will work best for your application.

In most applications, cleaning of the chimney system will be easiest from the top (chimney cap) down. If this is the planned method for your application, the center iron pull down handle on the flue collar serves as protection to keep prevent a chimney brush from damaging the baffle inside the stove. If cleaning can only take place from inside the home, the center bar may be cut out of the flue collar using a hack saw or reciprocating metal cutting saw.

4. Install the venting system: Again, depending on your application it may be easiest to install the connector or stainless steel flue liner in the chimney first. Refer to Figure 6 for the components of the venting system.

- Carefully remove the fiber baffle by first removing the front air tube. If necessary, removing the remaining air tubes will allow easier access.
- Remove the iron flue collar from the stove and fasten either the adapter pipe or flue liner to it by drilling three holes using the holes in the iron collar as a guide.
- Secure the flexible pipe to the pipe adaptor using the same method.
- Install the connector pipe or liner so that the height measured from the finished hearth surface to the center bar of the flue collar is 19" (483 mm). (Fig. 7) This will allow an easy connection once the stove is rolled into place.

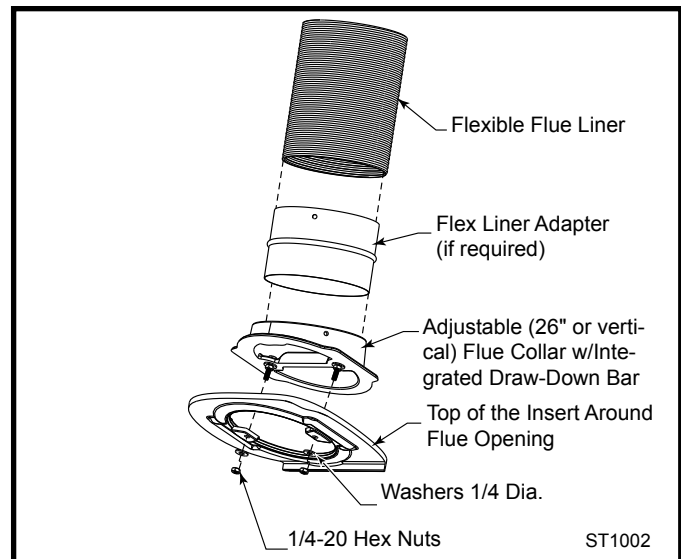

Fig. 6 Components of the venting system.

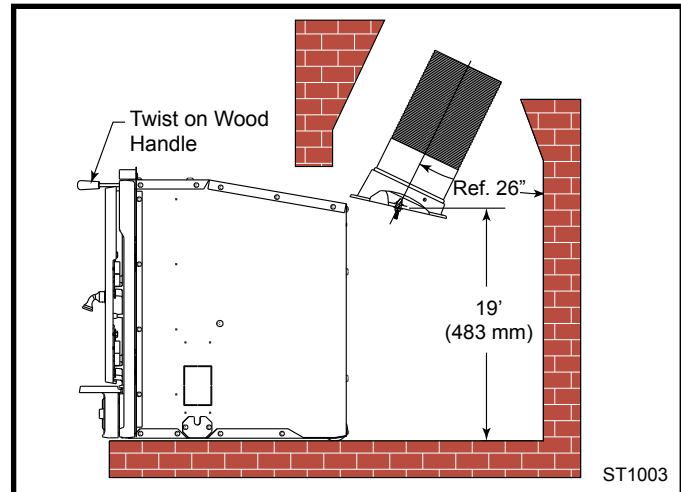

Fig. 7 Measured height from the finished hearth surface to the center bar of the flue collar.

5. Route the blower power cord. Run the power cord out the left or right side of the insert. Remove the cover plate and insert the provided grommet into the slot. Reattach the cover plate.

NOTE: DO NOT RUN THE POWER CORD UNDER OR IN FRONT OF THE UNIT.

6. Install the Optional Surround Kit. Follow the instructions provided with the kit.

7. Roll the Firebox into Position. At least two people will be needed to move the firebox. Lift the front of the stove slightly to put weight on the rear wheels to ease installation. Position the firebox so the flue collar lines up with the connector. Use the leveling screws at the front of the Insert to adjust the level. Route the power cord to the side nearest the power supply and test the fans.

8. Connect the Flue Collar. : From inside the stove, reach up and pull the flue collar into place by lining up the two 1/4" studs in the stove top. Care should be taken to not disturb the gasket which seals the collar to the top. Tighten the two 1/4" nuts.

- Replace the three rear stainless steel air tubes by sliding them first to the right and then into the mating holes on the left. Secure these in place with the stainless steel cotter pins.
- Before installing the front air tube, replace the fiber baffle board and ensure it slides all the way to the back. There should be a tight fit between the board and the iron sides of the stove.
- Replace the front air tube and secure it in place with the cotter pin.

9. Connect the Blower power cord to the power supply. DO NOT ROUTE THE POWER CORD UNDER OR IN FRONT OF THE UNIT.

10. Install the supplied wooden handle by twisting clockwise onto the primary air control. (Fig. 7)

This completes installation of your Montpelier Medium Insert.

Smoke and CO Detectors

The use of smoke and carbon monoxide (CO) detectors throughout the home is strongly advised, even if not required by building codes or insurance regulations. It is a good idea to install a smoke detector in the living areas and each bedroom. Follow the smoke/CO detector manufacture's placement and installation instructions and maintain regularly.

You may not, however, wish to install a detector in the immediate vicinity of the Montpelier insert. Depending on the sensitivity of the unit, the alarm can be set off while you are tending the fire or emptying the ashes. If you install a detector in the same room, locate it as far away from the insert as possible.

Safety Tips

Conveniently locate a "Class A" fire extinguisher to contend with small fires. Be sure the fire extinguisher works and is clearly visible. All occupants of the house should know where it is, and how it operates. Have heavy stove gloves available near the insert. Have special safety accessories (e.g., Child Guard Screen) available for use if small children will be in the home.

In the event of a stove pipe or chimney fire....

- Evacuate the house immediately
- Notify the fire department
- If the fire isn't too threatening, closing down the insert tight, (damper, primary air, all doors) will help to smother the fire.
- Inspect your insert, stove pipe and chimney for any damage caused by the fire and correct any damage before using your insert again.

Operation

Your Insert's Controls and What They Do

All Montpelier Medium Insert controls are conveniently located on the front. (Fig. 8)

Two controls regulate the performance of your Montpelier Medium Insert:

The **primary air control** supplies oxygen for the fire.

The variable-speed **fan control**, or rheostat, regulates the warm air flow into the room.

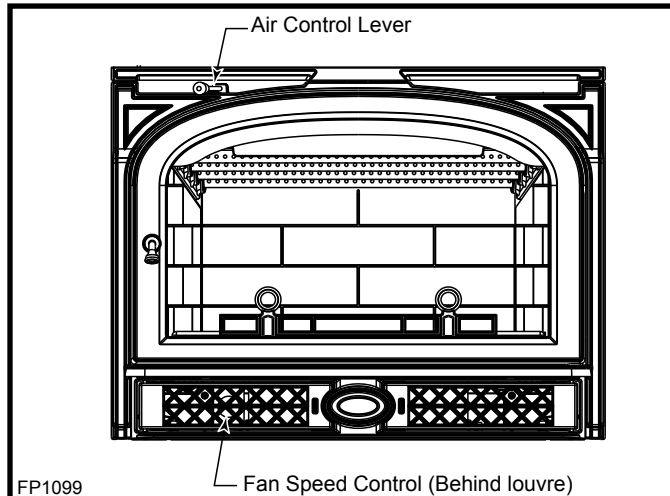

Fig. 8 Montpelier Medium Insert controls.

Primary Air Control

A single air control regulates the amount of heat the fire will produce and how long it will burn.

The **primary air control lever** is located on the upper left side on the front of the insert. The lever regulates air for starting, maintaining, and reviving the fire.

Generally, more air entering the stove makes the fire burn hotter and faster, while less air prolongs the burn.

WARNING

This wood heater has a manufactured-set minimum low burn rate that must not be altered. It is against federal regulations to alter this setting or otherwise operate this wood heater in a manner inconsistent with operating instructions in this manual.

The Montpelier Medium Insert's air supply is increased when the control lever is moved to the left, and decreased when moved to the right. It may be set anywhere between the two extremes, depending on the amount of heat desired. (Fig. 9)

To complement the manual setting of the air control, the Montpelier Medium Insert has an integral convection air blower that ensures an even delivery of heat at the manual setting you select.

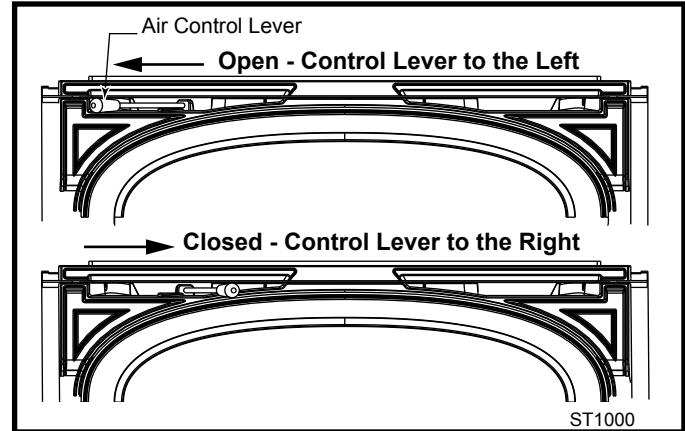

Fig. 9 The air control lever controls the amount of air entering the firebox.

The Fans

The convection fan delivers a steady stream of warm air into the room. Use the fan speed control to regulate the flow of air into the room. A thermal switch will automatically deactivate the fan when the stove cools down. When starting a fire in a cold stove, this switch will typically energize the fan within about 60 minutes depending on wood species and fuel load.

The fan speed should be set at "low" (fully closed) when operating at low to medium burn rates and may be set anywhere between "low" and "high" when operating at high burn rates. (Refer to Figure 10 for fan access)

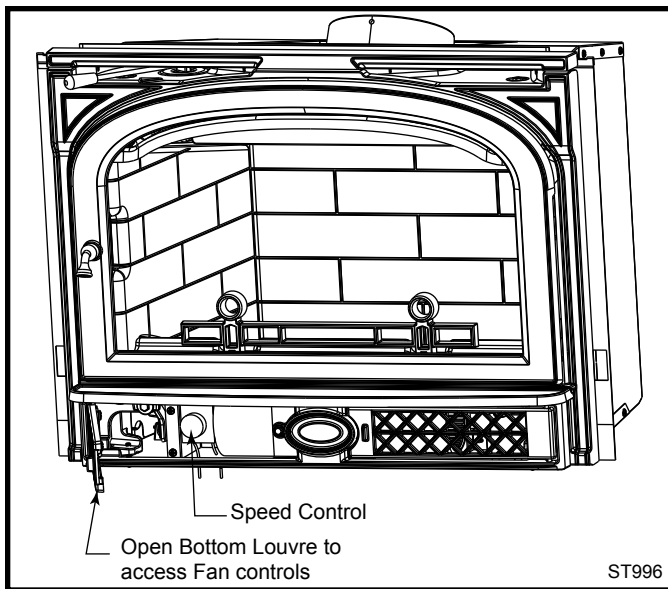

Fig. 10 Fan control access.

Burn Only High-Quality Wood

The Montpelier Medium Insert is designed to burn natural wood only; do not burn fuels other than that for which it was designed.

You'll enjoy the best results when burning wood that has been adequately air-dried. Avoid burning "green" wood that has not been properly seasoned or cordwood that is more than two years old.

The best hardwood fuels include oak, maple, beech, ash, and hickory that has been split, stacked, and air-dried outside under cover for at least one to two years.

For areas that do not have a supply of hardwood, commonly burned softwoods include tamarack, yellow pine, white pine, Eastern red cedar, fir, and redwood. These too should be properly dried.

Your Montpelier Medium Insert will accept wood up to 18" (460mm). Longer wood pieces work better than short ones.

Wood should be stored under cover to maintain dryness. Even for short-term storage, however, keep wood a safe distance from the heater and keep it out of the areas around the heater used for re-fueling and ash removal.

Use the Air Control Settings that Work Best for You

No single air control setting will fit every situation. Settings for each installation will differ depending on the quality of the fuel, the amount of heat desired, and how long you wish the fire to burn.

The control setting also depends on your particular "draft," or the force that moves air from the stove up through the chimney. Draft is affected by such things as the length, type, and location of the chimney, weather, local geography, nearby obstructions, and other factors.

Too much draft may cause excessive temperatures in the Montpelier Medium Insert, and could even damage internal components. On the other hand, too little draft can cause backpuffing into the room or a very sluggish fire.

How do you know if your draft is excessively high or low? Symptoms of too much draft include an uncontrollable burn or glowing-red cast iron. A sign of inadequate draft is smoke leaking into the room through the stove or chimney connector joints, low heat, and dirty glass.

In some newer homes that are well-insulated and weather-tight, poor draft may result from insufficient air in the house. In such instances, an open window near the stove on the windward side of the house will provide the fresh air needed.

When first using the stove, keep track of the settings of the air controls. You will quickly find that a specific setting will give you a fixed amount of heat. It may take a week or two to determine the amount of heat and the length of burn you should expect from various settings.

Most installations do not require a large amount of combustion air, especially if adequate draft is available. **Do not for any reason attempt to increase the firing of your heater by altering the air control adjustment range outlined in these directions.**

Use the following primary air control lever and fan speed control lever settings as a starting point to help determine the best settings for your installation.

Montpelier Medium Insert Control Settings

Primary Air		Air Circulation	
Burn Rate	Control Setting	Fan Speed	Control Position
High	Fully left	High	Horizontal
Medium full right	1" from	Low	Turn clockwise
Low	Fully right	Off	Turn counterclockwise

Starting and Maintaining a Wood Fire

Burn solid wood fuel only in the Montpelier Medium Insert, and burn it directly on the grate. Do not elevate the fuel. Do not burn coal or other fuels.

Cast iron is a superior material for solid fuel stoves but it must be treated with respect. It is extremely strong, but can be broken with a sharp blow from a hammer or from the thermal shock of rapid and extreme temperature changes. It is important to temper the cast iron plates with an initial series of 3-4 break-in fires. The plates expand and contract with changes in temperature. Minimize thermal stress by allowing the plates to adjust gradually during the break-in fires by following Steps 1-3 on the following page.

WARNING: Operate your Montpelier Medium Insert only with the door fully closed. If the door is left partially open, gas and flame may be drawn out of the fireplace opening, creating risks of both fire and smoke.

Follow these guidelines as you start and maintain the fire, and remove the ashes. Prior to starting a fire with a cold stove, it is recommended to clear the lower primary air holes located under the front brick. To do this, remove the andiron and lift out the front refractory brick. Sweep any ash accumulation out of the three (3) air slots. Keeping these slots clear of ash will ensure better performance.

1. Open the primary air control fully.
2. Lay some crumpled newspapers in the bottom. Place on the paper six or eight pieces of dry, finely-split kindling. On the kindling lay two or three larger sticks of split dry wood approximately 1-2" (25-50 mm).

Do not use chemicals or fluids to start the fire. Do not burn garbage or flammable fluids such as gasoline, naphtha, or engine oil. Also, never use gasoline-type lantern fuel, kerosene, charcoal lighter fluid, or similar liquids to start or "freshen up" a fire in this heater. Keep all such liquids well away from the heater while it is in use.

3. Light the newspaper and close the door. Gradually build up the fire by adding a few 3-5" (76 -127 mm) diameter splits.

If this is your initial break-in fire, let the fire burn brightly, but not to excess. Control the fire's intensity by adjusting the air control lever. After an hour or so stop adding wood so that the fire dies out gradually.

For ongoing operation after the initial break-in, continue to add a few sticks at a time of a progressively larger size. Be sure to keep the fuel load behind the front grate bar at all times. Continue until you have a live ember bed at least 3-4" (76 - 102 mm) deep. This may take an hour or longer, particularly when the Montpelier Medium Insert is vented to an exterior masonry chimney or when you are just starting a fire.

NOTE: Effectiveness of a "top-down" method to start a fire. Smoke emissions when starting a fire can be difficult to control because the insert is not yet heated to its optimum temperature. One method of reducing emissions during a cold start-up is the use of a "top-down" kindling procedure. In this, place larger pieces of kindling on the bottom of the kindling pile followed by smaller and smaller pieces as the pile is added to. Very finely split pieces should be on the top. Light the kindling pile with a match at the top and allow the kindling to burn downward into the larger pieces. This reduces smoke by slowly increasing the fire size without creating an air-starved condition.

You'll soon find that the insert is **HOT WHILE IN OPERATION! KEEP CHILDREN, CLOTHING, AND FURNITURE AWAY. CONTACT MAY CAUSE SKIN BURNS.**

NOTE: Some chimneys need to be "primed," or warmed up, before they will draw sufficiently to start a fire. To correct this situation, roll up a couple pieces of newspaper, place them on top of the kindling and toward the back of the stove, light them, and close the doors. This should heat the chimney enough to initiate a draft.

Once the draft is established, open the front door and light the rest of the fuel from the bottom. Do not light the main bed of fuel until the chimney begins drawing, and repeat the procedure as often as necessary if the initial attempt is unsuccessful.

4. Once a good ember bed of at least 3-4" (76 - 102 mm) has formed, add the desired amount of wood and close the primary air control to a medium-low setting. The fire volume will diminish immediately, but the Montpelier Medium Insert will continue to heat up. Maintain control of the fire using the primary air control, and remember: reduce the setting for less heat, increase the setting for more heat. Refer to the air control settings chart on Page 11 for recommended settings at different burn rates.

Do not over-fire this heater.

Overfiring may cause a house fire, or can result in permanent damage to the stove. If an exterior part of the Montpelier Medium Insert glows, you are overfiring.

Reloading and Reviving a Wood Fire

Set the air control on "High," and wait at least fifteen seconds for the draft to increase. Turn the convection blower off. Open the door slowly.

IMPORTANT: While the stove is hot, toss and sift the coals with each stove loading. This loosens and helps burn coals that become buried in the ash. Push coals away from the three bottom air jets. Creating this "void" helps maintain a reliable fire.

Check the ash level, and remove excess ash. Three (3) primary air holes located under the front brick provide air to the coal bed. (Fig. 11) These holes should be cleared of ash for proper performance.

Add the fuel, smaller pieces first. If it is necessary to use wood smaller than the 18" (460 mm) optimum size, be sure to fill the firebox as completely as possible by loading the wood pieces alternately on the left and right. Split wood will fill the firebox more completely and reduce the frequency of reloading. If possible, stack wood diagonally to maximize air spaces between fired pieces.

If you have an ember bed of at least 2-3" (51 - 76 mm), the air setting may not need to be adjusted. If the ember bed is less than 2-3" (51 - 76 mm), you may have to leave the

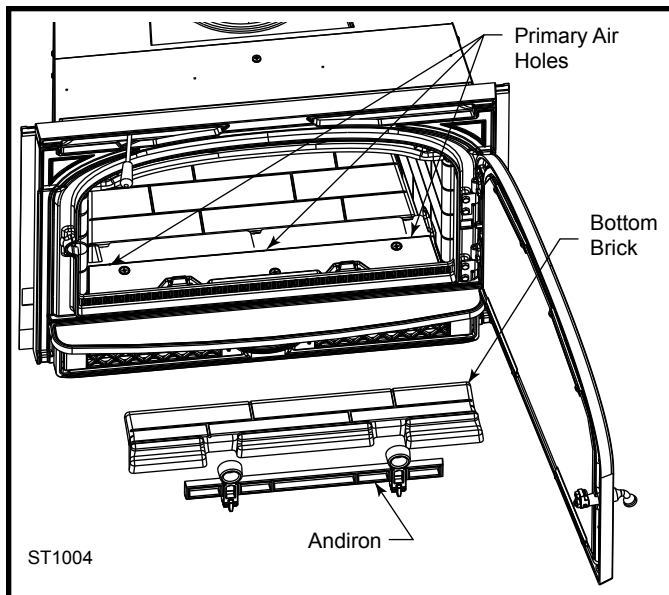

Fig. 11 Keep primary air holes free of ash for proper performance.

air setting on high for a few minutes until flames appear. Finally, adjust the air control and fan speed for your desired heat level.

NOTE: If the charcoal bed is relatively thick and your fuel is well-seasoned, it is possible to add fresh fuel (smaller pieces first), close the door, and reset the air control immediately.

Special Tactics for Cold-Climate Heating

The Montpelier Medium Insert is capable of producing up to 40,000 Btu/hour and heating an area of up to 1,500 sq. ft. However, many factors affect heating performance and can influence the extent to which the Montpelier Medium Insert can heat a given area.

A well-insulated home, located in a moderate climate and with the Montpelier Medium Insert located centrally in an open floor plan, will be easier to heat than a drafty home in the far north in which a Montpelier Medium Insert is installed on an exterior wall at the end of a long house.

In Fireplace Insert installations, over-sized chimneys can produce less effective results than those that are properly sized, and interior chimneys usually perform better than those located outside the house.

Different results may be experienced even in the same installation if you switch from burning good, dry wood to wood that is partially rotted or inadequately seasoned.

To compensate for these factors in cold climates, it may be necessary to operate the Montpelier Medium Insert for longer periods of time with the air control set to a higher level more of the time.

Remove and Store Ash Safely

Check the ash level before reloading the stove, remove ashes if necessary. Turn off the fan before shoveling the ash into your ash container.

Remove ash regularly, typically every one to three days. The frequency will vary depending on how you operate your Montpelier Medium Insert; more wood is consumed at higher heat output settings, and ash will accumulate faster.

Disposal of Ashes - Ash should be removed frequently and placed outdoors in a metal container with a tight-fitting lid. The closed container of ash should be placed on a non-combustible floor or on the ground, well away from all combustible materials, pending final disposal. If the ash is disposed of by burial in soil or otherwise locally dispersed, it should be retained in the closed container until all cinders have thoroughly cooled. Wood ash may be used as a garden fertilizer.

CAUTION: Never use your household or shop vacuum cleaner to remove ash from the fireplace; always remove and dispose of the ash properly.

Maintenance

Keep Your Montpelier Medium Insert Looking New and Working Its Best

Care of the Cast Iron Surface

An occasional dusting with a dry rag will keep the painted cast iron of your Montpelier Medium Insert looking new.

If the paint needs retouching, first allow the surface to cool completely. Mask glass, trim parts and enamelled areas. Wire-brush those areas to be painted. Touch-up with high temperature stove paint available from your local dealer. Apply the paint sparingly. Two light coats are better than one heavy one.

Care of the Porcelain Enamel Surface

Use a soft brush as necessary. Do not use water or other liquids on your Montpelier Medium Insert. Fingerprints usually can be buffed off porcelain enamel with a dry, soft cloth. If marks remain, allow the Montpelier Medium Insert to cool completely, then buff with a slightly damp, soft cloth. Dry completely before starting a fire to avoid streaking.

Never use abrasives or harsh chemical cleaners on the porcelain enamel finish; the enamel may scratch and expose the cast iron, which can then stain or rust. If you must remove spills or stains from porcelain surfaces, make sure the fire is out and the Montpelier Medium Insert has cooled completely before cleaning. Use a kitchen appliance cleaner and/or polish specifically formulated for enamel surfaces. Apply the cleaner sparingly with a soft cloth, and buff away all traces.

Cleaning the Glass

The Montpelier Medium Insert glass system requires a minimum amount of cleaning. Most carbon deposits that accumulate will burn off during hot fires.

Ash residue that accumulates on the glass should be removed periodically to prevent etching. To clean the glass, use the following procedure.

- Be sure the glass is completely cool.
- Cleaning with water will work in most cases. Use a glass cleaner especially made for this purpose only if deposits are specially heavy. (If heavy deposits are a frequent occurrence, however, evaluate your operating techniques.) Do not use abrasive cleaners.
- Rinse the glass thoroughly.
- Dry the glass completely.

Adjust the Door Latch Periodically

The front door of the Montpelier Medium Insert should close securely to prevent accidental opening and should close tightly to prevent air from leaking into the fire chamber. The door handle will be positioned vertically when the door is closed.

Over a period of time, the gasket around the door will compress and the latch may need adjustment. To adjust the handle, follow this procedure:

1. Loosen the small lock nut with a 7/16" wrench. (Fig. 12)
2. Extend the striker screw one turn by turning it with a 1/8" Allen wrench.
3. Re-tighten the lock nut, while at the same time holding the striker screw with the Allen wrench to prevent its turning.

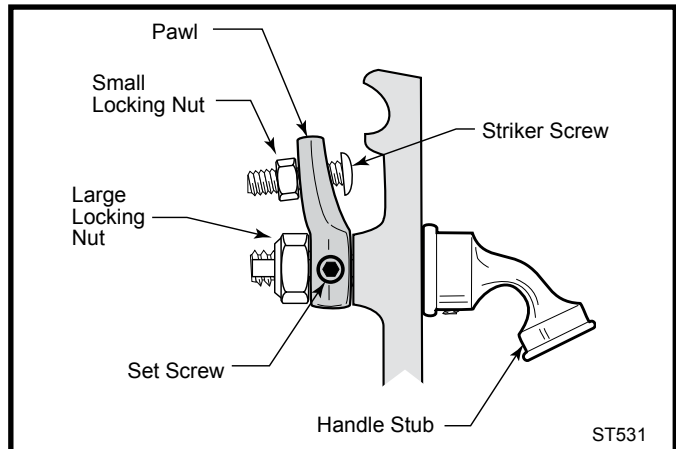

Fig. 12 Turn the door latch striker screw in or out to tighten or loosen the door latch.

Test the door seal. Close the door on a dollar bill and attempt to pull it free. If the bill is freed with little resistance, the gasket isn't snug enough at that spot. Continue to make small adjustments until the setting is right.

If additional adjusting of the latch does not enable the door to seal sufficiently in one area, try "adjusting" the gasket in that area. Pack more cement or a smaller diameter gasket into the channel beneath the gasket so the main gasket is raised and makes contact with the door frame. If this procedure doesn't solve the problem, replace the gasket. Instructions for gasket replacement are given later in this section.

IMPORTANT NOTES

- Do not operate the Montpelier Medium Insert if the glass is damaged or broken.
- Do not abuse glass by striking with any object or by slamming the door.
- Replace glass only with Vermont Castings Group high temperature ceramic glass, available from your Vermont Castings' authorized dealer.

! WARNING



HOT GLASS WILL CAUSE BURNS.
DO NOT TOUCH GLASS UNTIL COOLED.
NEVER ALLOW CHILDREN TO TOUCH GLASS.

Removing and Replacing Door Glass

Follow this procedure to replace glass.

- Open the door and loosen the four retaining clip screws that hold the glass to the door. Swing the clips out of the way. Tilt the glass away from the door frame and lift up. (Fig. 13) Wear gloves and use caution when handling broken glass.

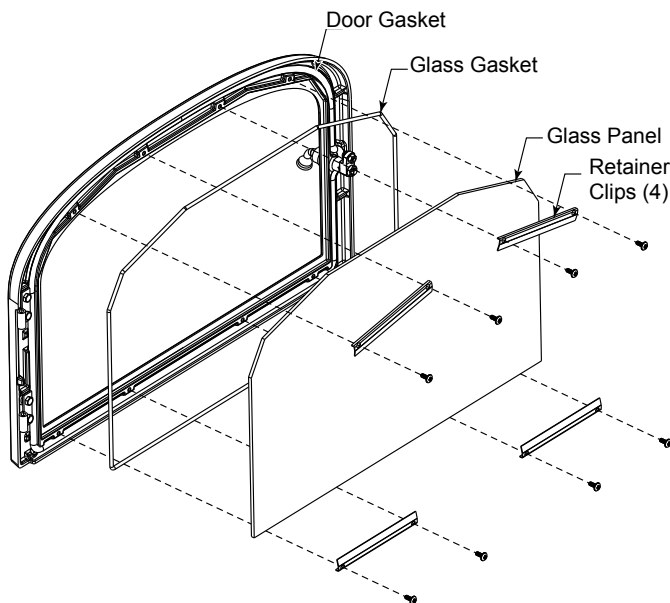

ST999

Fig. 13 Replace glass.

- Examine the gasket that seals the glass to the door frame. If necessary, replace this with gasket obtained from your local Vermont Castings' authorized dealer. Directions for replacing gaskets are given below.
- Check the channel at the bottom of the door frame, and clear away debris if necessary.
- Carefully place the new glass in the door frame.
- Secure the clips, being careful not to over-tighten. Be sure the glass is firmly seated against the gasket. Close the door gently to confirm the clips have been properly positioned. It is possible for the glass to be damaged if the clips have been installed incorrectly and the door is closed with force.

How to Replace Gaskets

Your Montpelier Medium Insert uses rope-type fiberglass gaskets to make a tight seal between some parts. With use, particularly on those parts that move, gaskets can become brittle and compressed and can begin to lose their effectiveness. These will need periodic replacement.

All of the gaskets used are made of fiberglass. The three sizes of replaceable gasket are listed below, along with their application.

Replaceable Montpelier Medium Insert Fiberglass Gaskets

Gasket Size	The Parts It Seals
3/8" (1203564).....	Door to the front – 5.6'
3/8" (30002422).....	Firebox parts
3/16" (1203556).....	Glass to the door – 5.2'

To change a gasket, wait until the fire is out and the stove has cooled. Wear protective eyewear and a dust mask. The procedure is the same for all gaskets.

1. Remove the existing fiberglass gasket by grasping an end and pulling firmly.
2. Use a wire brush or the tip of a screwdriver to clean the channel of any remaining cement, silicone or bits of gasket.
3. Apply a thin bead of high temperature silicone to the newly-cleaned groove. A 1/8" - 3/16" bead is sufficient.
4. Place a new gasket into the groove. Wait until you have placed all but a couple inches from the end before you trim the end to an exact fit.

Replacing the Door Gaskets

- Remove the door by lifting it straight up from its hinge pins.
- Lay it face down on a padded surface.
- Remove the glass. Follow the instructions for removing and replacing glass which start on Page 15.
- Replace gaskets. Follow steps 1-4, above.
- Replace the glass.
- Replace the door.

The Chimney System

A Clean Chimney System is Safer and Works Better

Although the non-catalytic combustion system in your Montpelier Medium Insert can reduce creosote formation dramatically, it is not a substitute for regular inspection and cleaning of the chimney and chimney connector.

Learn to Recognize — And Avoid — Creosote

Your Montpelier Medium Insert has been designed to minimize creosote build-up. Regular chimney inspection and maintenance, however, must still be performed. For safety, good stove performance, and to protect your chimney and chimney connector, inspect your chimney and chimney connector on a regular schedule. Clean the system if necessary. Failure to keep the chimney and connector system clean can result in a serious chimney fire.

Creosote - Formation and Need for Removal - When wood is burned slowly, it produces tar and other organic vapors, which combine with expelled moisture to form creosote. The creosote vapors condense in the relatively cool chimney flue of a slow-burning fire. As a result, creosote residue accumulates on the flue lining. When ignited, this creosote makes an extremely hot fire. The chimney and chimney connector should be inspected at least once every two months during the heating season to determine if a creosote buildup has occurred. If creosote has accumulated, it should be removed to reduce the risk of a chimney fire.

If you do experience a chimney fire, act promptly to:

- Close the primary air control lever (fully to the right).
- Get everyone out of the house.
- Call the Fire Department from a nearby house.

You should inspect the system every two months during the heating season as part of a regular maintenance schedule. To inspect the chimney, let the Montpelier Medium Insert cool completely. Then, using a strong light, sight up through the flue collar into the chimney flue. The fiber baffle will need to be removed gently to view inside the connector pipe.

If it is necessary to remove the firechamber to inspect or clean the chimney, this is how to do it:

- Let the Montpelier Medium Insert cool.
- Disconnect the fan power cord.
- You may wish to lighten the firebox by removing the load door and andiron.
- Retract the two levelling screws until they bear no weight.
- Remove the front air tube and fiber baffle.
- Disconnect the flue collar or vent connector from the top of the stove.
- Slide the firechamber forward until you have access to the fireplace opening.
- Inspect the flue.

You can now inspect the smoke shelf area of the fireplace and the chimney. Before replacing the Montpelier Medium Insert, this area should be inspected for signs of deterioration and cleaned thoroughly with a chimney brush.

Clean the chimney using a specially designed brush the same size and shape as the flue liner. Flexible fiberglass rods are used to run the brush up and down the liner, causing any deposits to fall to the bottom of the chimney where they can be removed through the clean-out door.

The chimney connector should be cleaned by disconnecting the sections, taking them outside, and removing any deposits with a stiff wire brush.

Reinstall the connector sections after cleaning, being sure to secure the individual sections with sheet metal screws.

If you can't do the chimney inspection yourself, contact your local Vermont Castings' Authorized Dealer, or engage a professional chimney sweep to perform the inspection and cleaning of the chimney.

Reverse the procedure to re-install the firechamber.

Fireplace System Maintenance Schedule

Fireplace:

Daily:

- Ash should be removed before the level reaches the top edge of the front brick. Check each time you re-load, or at least once a day.
- Keep the area around the fireplace clear of any combustible material.

Yearly Spring Cleaning:

- Remove ash from the firebox and replace with a moisture-absorbing material (such as kitty litter) to keep the interior of the stove dry.
- Touch up painted surfaces with black paint.

Flex Connection:

Two Months:

- Inspect the chimney and flue connection. Clean the system if necessary.

Yearly Spring Cleaning:

- Disassemble the flue connection and take it outdoors for inspection and cleaning. Replace weak sections of connector.
- Inspect the chimney for signs of deterioration. Repairs to a masonry chimney should be made by a professional mason. Replace damaged sections of prefabricated chimney. Your local Vermont Castings' dealer or a chimney sweep can help determine when replacement is necessary.
- Thoroughly clean the chimney.

For parts and information about your insert, contact your Vermont Castings authorized dealer. For the name of the dealer nearest you, contact:

Vermont Castings Group
 149 Cleveland Drive
 Paris, KY 40361
 800-668-5323

In the event of component failure, it is very important to replace with equipment equivalent to the Vermont Castings original parts.

Optional Accessories

Georgian Cast Surround

Model	Color
30DVSGTKCB	Classic Black
30DVSGTKBM	Brown Majolica

Mead Cast Surround

Model	Color
MEAD3CB	Classic Black
MEAD3BM	Brown Majolica

Caprice Cast Adjustable Profile Surround

Model	Color
CAPCB	Classic Black

Steel Surround

Model	Color
LHE30SSB	Classic Black (Small)
LHE30SLB	Classic Black (Large)

Extended Trim Plate

LHE30TCK (Cannot be used alone)

DIY Inside Fit Surround Kit

DIYSK - Includes template, brackets and instructions. Additional materials must be purchased locally.

3" Extension Package

Model	Color
M3PKCB	Classic Black

Trim Kit Base Risers (for use with most surrounds)

Model
LHE30R1 (1" Black)
LHE30R2 (2" Black)
LHE30R5 (5" Black)

Note: Trim kit base risers are not for use with the M3P-KCB Montpelier 3" Projection Kit.

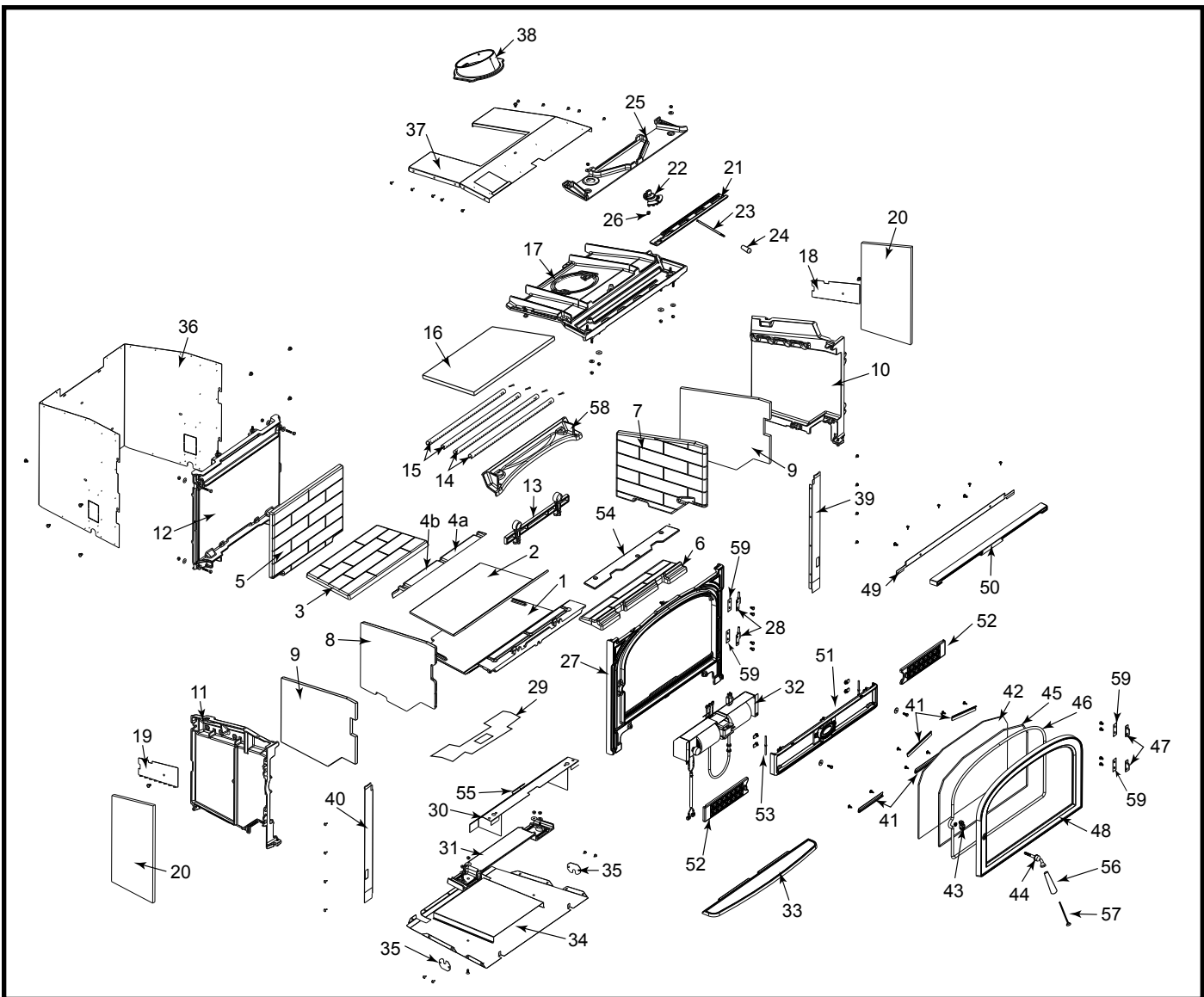

Vermont Castings Group reserves the right to make changes in design, materials, specifications, prices and discontinue colors and products at any time, without notice.

Montpelier Medium Insert

Ref.	Description	Part Number
1.	Bottom	30004306
2.	Insulation, Bottom Low	30004335
3.	Brick, Bottom Low	30004327
4a.	Brick, Bottom Slanted Right	30006706
4b.	Brick, Bottom Slanted Left	30006707
5.	Brick, Back	30004326
6.	Brick, Bottom Up	30004329
7.	Brick, Right End	30004330
8.	Brick, Left End	30004331
9.	Insulation, End Int.	30004334
10.	End, Right	30004308
11.	End, Left	30004309
12.	Back	30004307
13.	Andiron	30004321
14.	Tube A, Secondary Air Tube	30004377

Ref.	Description	Part Number
15.	Tube B, Secondary Air Tube	30004378
16.	Baffle	30004332
17.	Top	30004310
18.	Right Side Heat Shield, Secondary Air	30004501
19.	Left Side Heat Shield, Secondary Air	30004500
20.	Insulation, End Ext.	30004333
21.	Air Plate	30004315
22.	Pinion	30004320
23.	Handle Wire	1604504
24.	Handle, Wood Black	1600663
25.	Cover, Top	30004316
26.	Spring, Friction	1201846
27.	Front	Refer to Enamel Parts Chart
28.	Hinge Half Body - Upper	1604281
29.	Insulation Bottom Heat Shield	30004402

Montpelier Medium Insert (continued)

Ref.	Description	Part Number
30.	Bottom Heat Shield	30004393
31.	Base	30004313
32.	Fan Kit Assembly	30004416
	Replacement Blower only	30004412
	Snapstat Wire Assy	30004406*
	Snapstat Wire Assy	30005535
	Rheostat and Wire Assy	30004407
	Power Cord	1601482
	Snapstat	51704
	Snapstat Bracket	30005538
	D Knob	1604419
33.	Ashlip	Refer to Enamel Parts Chart
34.	Bottom Assembly	30004797
35.	Cover, Power Cord	30004379
36.	Shroud, Outer	30004392
37.	Shroud, Top	30004614
38.	Flue Collar	30004317
39.	Flange Right Side Surround	30004381
40.	Flange Left Side Surround	30004380

Ref.	Description	Part Number
41.	Clip - Glass	30001715
42.	Glass Ceramic, 0.190" thick, uncoated	30004325
43.	Pawl Assembly 1" Long Adjustable	30002362
44.	Front Steel Handle/Shaft	30002717
45.	Gasket Fiberglass 3/16	1203556
46.	Gasket Fiberglass 3/8	1203589
47.	Hinge Half Door - Upper	30004564
48.	Door	Refer to Enamel Parts Chart
49.	Flange Top Surround	30004382
50.	Filler Top	Refer to Enamel Parts Chart
51.	Panel	Refer to Enamel Parts Chart
52.	Panel Door	Refer to Enamel Parts Chart
53.	Pin, Door	30004384
54.	Cover Plate, Bottom Air	30004419
55.	Snapstat Bracket	30004519**
56.	Handle, Wood, Black	1600664
57.	Handle Screw	1201310
58.	Airwash	30004314
59.	Hinge Spacers	30004708

NOTES:

* Use if wire assembly is attached to firebox - Pre 2/24/11

** Use if bracket is attached to firebox - Pre 2/24/11

Shell Enamel Parts - Montpelier Medium Insert		
Part Name	Classic Black	Brown Majolica
Front	30004722	30004903
Door	30004312	30004908
Ashlip	30004322	30004904
Front Panel	30004323	30004905
Panel Door	30004324	30004906
Top Filler	30004336	30004902

Limited Lifetime Warranty

For Vermont Castings Montpelier, Non-Catalytic Medium Insert

Limited Lifetime Warranty

Vermont Castings Group warrants that all refractory brick and material used in this product will be warranted against deterioration not resulting from physical damage or overloading of the wood stove for the lifetime of this product. This coverage includes the components of the EverBurn System: shoe, fountain, and fireback. Coverage is provided only to the original purchaser.

Limited 3 Year Warranty

All cast iron parts are warranted for a period of three years against breakage, cracking or burn-through.

Limited 1 Year Warranty

The following part of the woodburning stove are warranted to be free of defects in material and workmanship for a period of one year from the date you receive it: The handles, glass door panels, door gasketing and porcelain finish. Any of these items found to be defective will be repaired or replaced at no charge, upon the return of the part with postage prepaid to a Vermont Castings Authorized Dealer.

Any parts repaired or replaced during the limited warranty period will be warranted under the terms of the limited warranty for a period not to exceed the remaining term of the original limited warranty or six (6) months, whichever is longer.

Exclusions & Limitations

1. This warranty is non-transferable.
2. This warranty does not cover misuse of the stove. Misuse includes overfiring, which will result if the stove is used in such a manner as to cause one or more of the plates to glow red. Overfiring can be identified later by warped plates and areas where the paint pigments has burned off. Overfiring in enamel stoves is identified by bubbling, cracking, chipping and discoloration of the porcelain enamel finish. Vermont Castings Group offers no warranty on chipping of enamel surfaces. Inspect your woodburning stove prior to accepting it for any damage to the enamel.
3. This warranty does not cover misuse of the stove as described in the Owners Guide, nor does it cover a stove which has been modified unless authorized by a Vermont Castings Group representative in writing. This warranty does not cover damage to the stove caused by burning salt saturated wood, chemically treated wood, or any fuel not recommended in the Owners Guide.
4. This warranty does not cover a stove repaired by someone other than a Vermont Castings Authorized Dealer.
5. Damage to the unit while in transit is not covered by this warranty but is subject to a claim against the common carrier. Contact Vermont Castings Authorized Dealer from whom you purchased your stove or Vermont Castings Group if the purchase was direct. (Do not operate the stove as this may negate the ability to process the claim with the carrier).

6. Claims are not valid where the installation does not conform to local building and fire codes or, in their absence, to the recommendations in our Owners Guide.
7. The salt air environment of coastal areas, or a high-humidity environment, can be corrosive to the porcelain enamel finish. These conditions can cause rusting of the cast iron beneath the porcelain enamel finish, which will cause the porcelain enamel finish to flake off. This warranty does not cover damage caused by a salt air or high-humidity environment.
8. Vermont Castings Group shall have no obligation to enhance or update any unit once manufactured.

IN NO EVENT SHALL Vermont Castings Group BE LIABLE FOR INCIDENTAL AND CONSEQUENTIAL DAMAGES. ALL IMPLIED WARRANTIES, INCLUDING THE IMPLIED WARRANTIES OF MERCHANTABILITY AND FITNESS, ARE LIMITED TO THE DURATION OF THIS WRITTEN WARRANTY. THIS WARRANTY SUPERCEDES ALL OTHER ORAL OR WRITTEN WARRANTIES.

Some states do not allow the exclusion or limitations of incidental and consequential damages or limitations on how long an implied warranty lasts, so the above limitations may not apply to you. This warranty gives you specific rights and you may have other rights, which vary from state to state.

How to Obtain Service

If a defect is noted within the warranty period, the customer should contact a Vermont Castings Authorized Dealer or Vermont Castings Group if the purchase was direct with the following information:

1. Name, address, and telephone number of the purchaser
2. Date of Purchase.
3. Serial number from the label on the back
4. Nature of the defect or damage.
5. Any relevant information or circumstances, e.g., installation, mode of operation when defect was noted.

A warranty claim will then start in process. Vermont Castings Group reserves the right to withhold final approval of a warranty claim pending a visual inspection of the defect by authorized representatives.



149 Cleveland Drive • Paris, Kentucky 40361
www.vermontcastingsgroup.com