

MENDOTA MODEL DXV-42 TOP VENT

USE ONLY DURAVENT 4"X6-5/8" COAXIAL PIPES AND VENTING COMPONENTS.

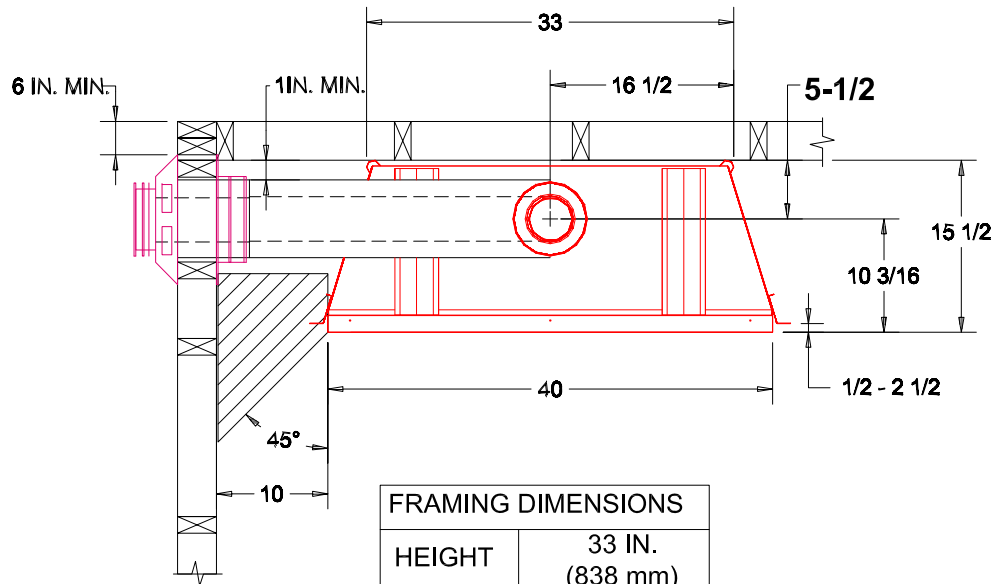

FRAMING DIMENSIONS	
HEIGHT	33 IN. (838 mm)
WIDTH	41 in. (1041 mm)
DEPTH	16 in. (406 mm)

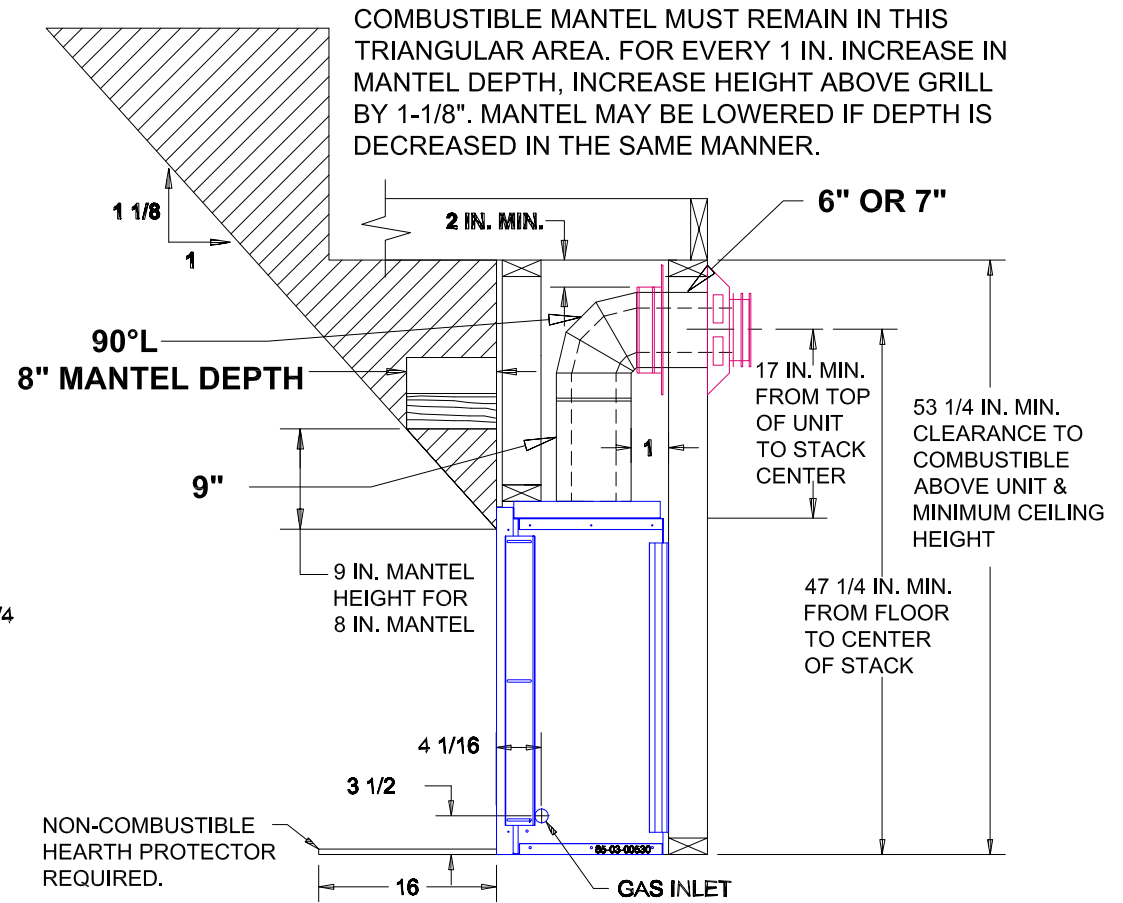
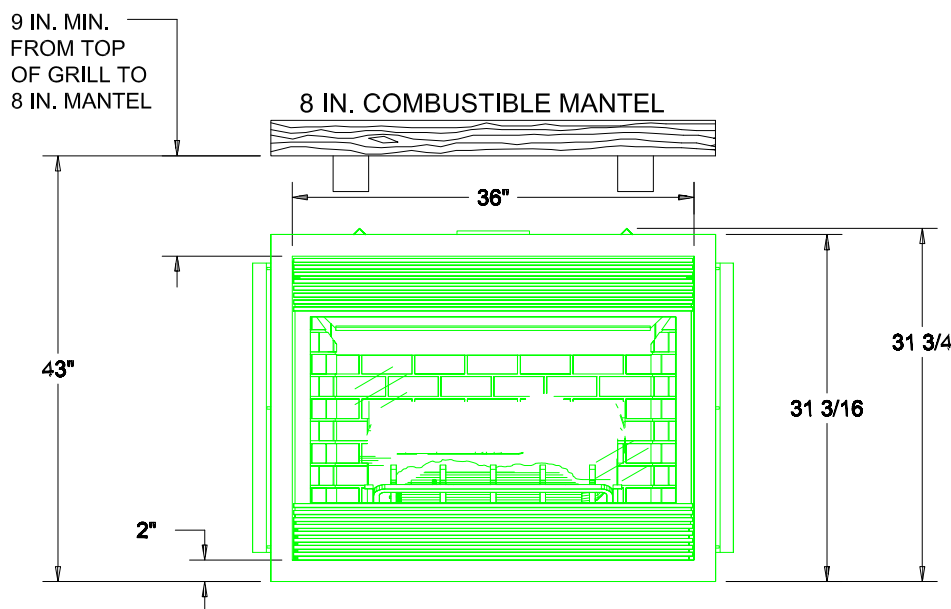
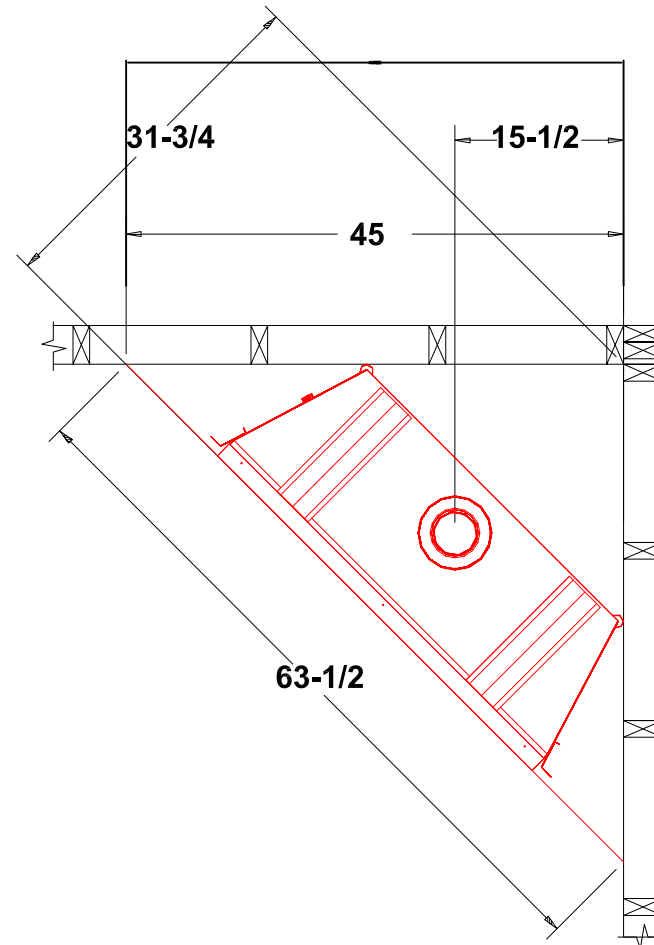

NON-COMBUSTIBLE HEARTH PROTECTOR REQUIRED.